

Design of Novel Precise Quadrature Oscillators Employing ECCIIs with Electronic Control

Roman SOTNER¹, Abhirup LAHIRI², Aslihan KARTCI³, Norbert HERENC SAR¹,
Jan JERABEK¹, Kamil VRBA¹

¹Faculty of Electrical Engineering and Communication, Brno University of Technology, Czech Republic
²36-B, J and K Pocket, Dilshad Garden, Delhi, India.

³Corlu Engineering Faculty, Namik Kemal University, Cerkezko y, Turkey
sotner@feec.vutbr.cz

Abstract—In this paper, an interesting design of precise quadrature oscillator employing electronically controllable current conveyors of the second generation (ECCII) is presented. The main purpose of this paper is to show advantages and features of direct electronic control of application by an adjustable current gain where help of signal flow graph approach was used to clearer and visual understanding of the design. The discussed circuit and its presented modification have several favorable features such as grounded capacitors, independent electronic adjusting of oscillation frequency and condition of oscillation by the current gain and easy automatic gain control circuit (AGC) implementation (non-ideal effects of tuning process on output amplitudes are suppressed). Oscillator was designed for frequency band of units of MHz and tested with two types of inertial AGCs. Theoretical presumptions were confirmed by laboratory experiments.

Index Terms—Direct electronic control, current gain adjusting, electronically controllable current conveyors, quadrature oscillators, signal flow graph approach.

I. INTRODUCTION

A. Overview of controlling possibilities in current conveyors and amplifiers

Current or voltage-mode integrators employing current conveyors CCII [1-4] are very often used in modern analog circuit design. However, resistors (in most cases grounded) or adjustable resistance of current input called R_X is the only way how to change the time constant. This parameter can be adjusted by the bias current I_b in limited range. This solution is very popular in novel on-chip implementations of new active elements. The examples of such elements, their definitions and descriptions can be found in [3-8]. Adjusting of current gain in current active elements and in current conveyors (CC) was firstly introduced in [9]. This approach is built on the adjustable transfer between X and Z ports in the CCII type. Authors defined so-called electronically controllable current conveyor of second generation (ECCII). There are already some works on this topic in the open

literature. Nevertheless, it is still not so common way how to adjust circuit parameters and many solutions still use the R_X (I_b) control. Minaei et al. [10] introduced novel element called ECCII, where current gain control was also possible. Similarly, Marcellis et al. in [11], Tangsrirat in [12], Shi-Xiang et. al in [13] and Herencsar in [14] proposed active elements with this useful feature. It provides interesting and special feature in many applications. In some recently published works that focus on the oscillator and filter design [14-25], the implementation of adjustable current gain (B_G) for control of parameters in application is quite a beneficial solution.

B. Recently reported oscillators employing current gains

We focused on state-of-the-art of oscillator solutions, which use current gain control for electronic adjusting in applications. Of course, there are many oscillators based on active elements working with different principles in contemporary literature. Hitherto published solutions employs such elements, e.g. transconductors (OTAs), current differencing transconductance amplifiers (CDTAs), current follower transconductance amplifiers (CFTA), and many others [3]. Our discussion will be specialized on solutions employing current-gain control.

This work focuses on oscillator design, where the main aim is the electronic control of oscillation frequency (f_0) and condition of oscillation (CO) using B_G simultaneously. Several hitherto published works were presented in this area. Souliotis et al. presented multiphase oscillator using lossy integrators based on the adjustable current amplifiers in [15]. All capacitors are grounded, CO and oscillation frequency are electronically and independently adjustable. The oscillator produces current output signals. Multiphase solution with cascade connection of lossy integrators based on translinear current conveyors (CCCII) was introduced by Kumngern et al. in [16]. Kumngern et al. also published work [17], where combination of both methods (intrinsic resistance and current gain control) was verified. A solution presented in [17] requires two active elements. CO is driven by current gain and f_0 by R_X (I_b). The oscillator does not provide quadrature outputs and linear control of f_0 . In [20], the ECCII was a functional part of modified active element, CCTA [3] and B_G control was used for the oscillation frequency adjusting in simple quadrature oscillator. Electronic control of f_0 is possible by B_G , but CO control is available only by adjusting of grounded resistor. It is a very simple solution employing only one active element, but

Research described in the paper was supported by Czech Science Foundation projects under No. 102/11/P489 and No. 102/09/1681. The support of the project CZ.1.07/2.3.00/20.0007 WICOMT, financed from the operational program Education for competitiveness, is gratefully acknowledged. The described research was performed in laboratories supported by the SIX project; the registration number CZ.1.05/2.1.00/03.0072, the operational program Research and Development for Innovation and supported by the project CZ.1.07/2.3.00/30.0039. This research work is also funded by projects EU ECOP EE.2.3.20.0094, CZ.1.07/2.2.00/28.0062.

there are some drawbacks in this solution. The first problem is dependence of one produced amplitude on tuning process (B_G which tunes f_0) and the second problem is nonlinear control of f_0 . Very interesting oscillator in [22] provides control of f_0 and CO by B_G , but these parameters are not independent and control of f_0 is also not linear. In addition, only one capacitor is grounded. Independence between f_0 and CO parameters was achieved in [23]. However, there is dependence of one of produced amplitudes on B_G under tuning process and control of f_0 is not linear. It is a problem of very simple solutions using minimal number of active elements and grounded capacitors. Current-gain control suitable for f_0 control was used also in [24] and [25] in quadrature oscillators employing so-called z-copy controlled-gain current-differencing buffered amplifier (ZC-CG-CDBA). The solution in [24] is based on two active elements and five passive elements (capacitors are grounded). Nevertheless, active element is quite complicated. Discrete model requires four diamond transistors [26-27] and voltage buffer, but it is not a problem for future on-chip implementation. The oscillation frequency is controllable by B_G linearly. CO and f_0 are completely independent. There is no dependence of output amplitude on tuning process. CO is controllable via floating resistors only (it is a small drawback of this solution). The authors used optocoupler for amplitude stabilization and automatic gain control circuit (AGC). The solution in [25] requires two ZC-CG-CDBAs and 6 passive elements (capacitors are also grounded). CO is also controllable by floating resistor, and f_0 is even adjustable digitally (dependence of f_0 on B_G is linear). Alzahr in [28] introduced interesting solution where digital adjusting of current gains was used to ensure linear f_0 control and simple CO control (both by current gains). Complexity of circuit is similar to the discussed solutions (four resistors, two grounded capacitors).

C. Our proposal and comparison

We can summarize the important features of previous works focused on current gain control for adjustability and tuning purposes. There is linear dependence of f_0 on B_G in our solution and output amplitude is not affected by tuning process in comparison to the work [17] or [20]. Only CO is controllable by B_G in [17]. In [20] is still necessary to control CO by adjusting of passive element. A very simple solution in [22] allows to control f_0 and CO by B_G , but f_0 is dependent on CO. Both parameters are independent in [23], but dependence of f_0 on B_G is not linear and one of output amplitudes is changing if f_0 is adjusted. Finally, in [24] and [25], there were many from previous drawbacks removed. However, CO is still controllable only by floating resistor. Digital control of current gain in order to adjust f_0 and also CO was introduced in [28]. There were also almost all drawbacks solved but solution requires four resistors and similar number of active elements as in our case. A digital discontinuous control of CO (by current gain) may not be the best solution. Accuracy and precision of AGC require also careful and soft gain adjusting to minimize fluctuances of output amplitudes and obtain acceptable THD. Continuous control is better and maybe simpler than digital control because appropriate bit resolution of gain control is necessary for soft adjusting of CO. Linear control of f_0 ,

mutual independence of CO and f_0 and direct continuous electronic control of f_0 and CO only by current gain (B_G) simultaneously are possible in our solution with respect to works discussed above. CO and f_0 are controllable by DC voltage and therefore easy implementation of inertial AGC is possible. There are no problems with dependences of one output amplitude on B_G . Our work practically complements the family of oscillators [22-25] employing current gain (B_G) for direct electronic control of oscillator parameters. Powerful approach using state variable methods ([29-31] for example) could also be used for this design and results should be identical. We can discuss examples regarding very impressive works written by Gupta et al. [29-30]. Many oscillator structures including current feedback amplifier based integrators (in fact) in the loops constructed by the state variable methods were introduced in both works [29-30]. Oscillators in [29] are simpler (only two active elements, grounded capacitors) than solution described in our contribution. Unfortunately, oscillators in [29-30] belong to single resistance controllable types (electronic control is more complicated) and relations between amplitudes exist in case of tuning. Both stable output amplitudes while oscillator is tuned are required in many communication systems [24]. It is not novelty of our solution but this requirement was not considered for oscillator synthesis in many hitherto published works. Clarity of signal flow graph methods and descriptions is more suitable for help with design, better understanding of the behavior in the circuit (direct and feedback branches) and correct insertion of controllable active elements to the circuit in order to control f_0 without influencing amplitudes through tuning process.

The main aim of this paper is not to propose novel method of synthesis. This work focuses on investigation of controllable features in oscillators employing electronically adjustable current conveyors with current gain control for precise quadrature oscillator design operating without standard problems (non-linear control of oscillation frequency and amplitudes dependent on tuning process) of many reported and simpler solutions. The main result of our proposal is novel and precise quadrature oscillator (based on clear design and principle of operation) with wideband and linear f_0 control, with easy implementation of AGC, acceptable THD level and unchangeable amplitudes during the tuning process.

The paper is organized as follows: Known ways of electronic control in current conveyors and amplifiers, recent progress in the oscillator design based on continuous current gain control and comparisons are introduced in the Introductory section. Proposed circuit and design steps are discussed in details in the Section 2. Specific design, real behavior and experimental results are summarized in the Section 3. Concluding notes are in the Section 4.

II. PROPOSED OSCILLATOR DESIGN

We used two types of active elements (current conveyors, see Fig. 1) in proposed oscillator. The first is electronically controllable current conveyor of second generation (ECCII) [9]. The function is described by quite common and simple equations (in ideal case): $V_Y = V_X$, $I_Y = 0$, $I_Z = -B_G I_X$. The current gain between X and Z ports is adjustable and voltage

gain (transfer) from Y to X port is fixed (equal to 1). The second type is well-known current conveyor of second generation (CCII+/-) [1-3] with one or two outputs of both polarities (Z+/Z-). Transfer between X and Z ports and between Y and X ports of CCII+/- are fixed (equal to ± 1): $V_Y = V_X, I_Y = 0, I_{Z+} = I_X, I_{Z-} = -I_X$.

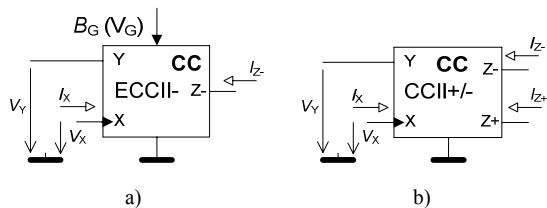

Figure 1. Current conveyors used in proposed oscillators: a) ECCII-, b) CCII+/-

Design was based on frequently used integrators (loss-less and lossy) in two feedback loops (similarly to multifunctional filters [32-37]). The first attempt [23] of design of this type oscillator was provided with only two ECCII- and one CCII+. The first ECCII allows to control f_0 and the second was used for CO control and future implementation of AGC. However, detailed analysis shows one disadvantage in [23], which is caused by driving gain B_G influencing the amplitude of produced signal (therefore amplitude changed with adjusting of f_0). While one of generated amplitudes has constant value, the second output amplitude is varying in dependence on tuning. Therefore, we improved this type of the oscillator in [23] and result is presented in this paper (two structures in Fig. 2 and Fig. 3). Our approach is based on the aid of signal flow graph (SFG) [38-39] which represents the two-loop circuit structure (Fig. 2) with current distribution [34], similarly as in [23]. The characteristic equation can be easily obtained by application of Mason rule [38-39] (Δ - determinant of SFG):

$$\Delta = 1 - (L_1 + L_2) = 1 - [F_1 H_1(s) H_2(s) + F_2 H_2(s)] = 0, \quad (1)$$

where

$$H_1(s) = k_1 \frac{1}{s}, \quad H_2(s) = k_2 \frac{1}{s + k_2} \quad (2), (3)$$

New modification (Fig. 3) contains additional ECCII, in order to eliminate the disadvantage of amplitude dependence and extend f_0 range of adjusting. Dependence of f_0 on $B_{G1,2}$ is linear, which is more suitable and typical in controllable oscillators. Simultaneous changes of two current gains $B_{G1,2}$ is the only disadvantage of this solution. Transfers of the branches have the following forms:

$$H_1(s) = \frac{B_{G1}}{sC_1R_1}, \quad H_2(s) = \frac{-R_2}{R_3(sC_2R_2 + 1)}, \quad (4), (5)$$

$$F_1 = -B_{G2}, \quad F_2 = -B_{G3}. \quad (6), (7)$$

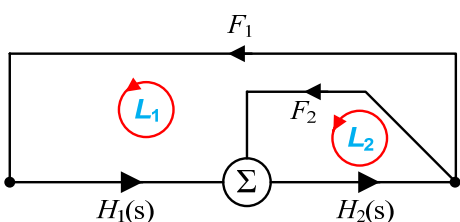

Figure 2. General two loop system

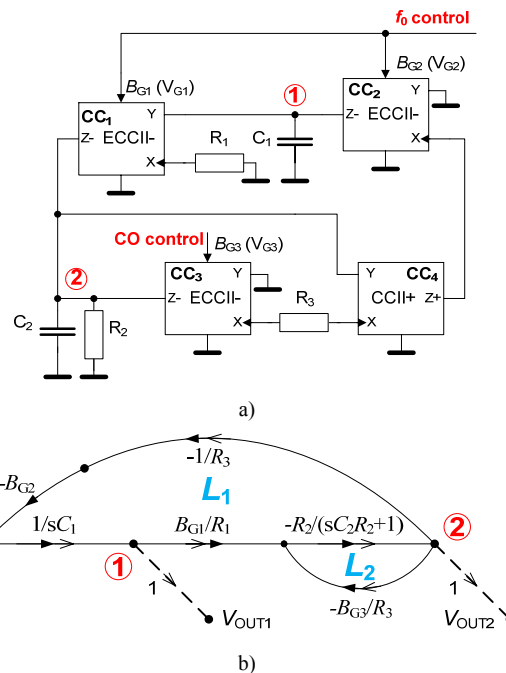

Figure 3. Proposed quadrature oscillator: a) circuit, b) detailed SFG

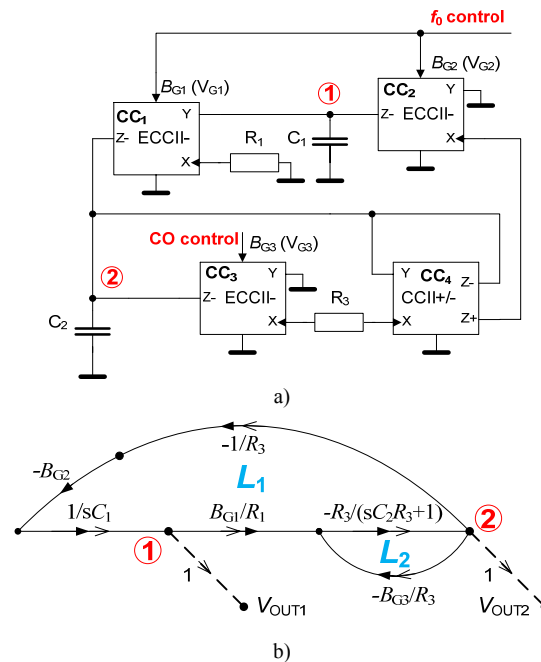

Figure 4. Proposed modified oscillator with reduced number of passive components: a) circuit, b) detailed SFG

We can discuss principle in more detail. In Fig. 3 we can see solution of the quadrature oscillator (autonomous circuit). Figure 3b shows simple signal flow graph (SFG), where conversion between voltage and current is documented by dotted and full arrows. The CC₁, CC₂ with R₁ and C₁ presents current-mode loss-less integrator. CC₄ and C₂, R₂, R₃ create lossy integrator (node 2). Useful feature of such integrator with current distribution (CC₃ + CC₄) is the possibility to change current gain of one path and therefore also gain of one feedback branch (CC₃ presents adjustable feedback path). Our requirement is to achieve solution without problem of varying amplitudes during the tuning process. Therefore, we need two adjustable parameters in large loop L₁ (F₁H₁H₂). Adjustable gain B_{G1} was implemented directly in current integrator

formed by CC_1 and R_1 and C_1 . Lossy integrator H_2 was not primary constructed as adjustable. Product of F_2H_2 must not include any adjustable parameter which is determined for f_0 control, as we can see from (1) and also from the example (8). Mutually independent control of CO and f_0 is the reason for this presumption. The second gain B_{G2} (CC_2) was solved as separate adjustable path (from output of CC_4 to node 1). Additionally, CC_2 could be considered as another complication (extra active element) but it brings also beneficial feature. Simultaneous adjusting of B_{G1} and B_{G2} allows linear and wide-range f_0 adjusting in comparison to the single-parameter-controllable oscillators and removes obstacle with amplitude dependences. The second loop created by F_2H_2 (1) has to ensure CO control without affection on f_0 . Separated feedback path created by CC_3 (B_{G3}) allows easy CO control, see (8). This step is really necessary. Therefore, we cannot use one simple CC instead of CC_3 and CC_4 . The characteristic equation of the oscillator in Fig. 3 has the following form:

$$\Delta_1 = 1 - (L_1 + L_2) = 1 - \left[-\frac{1}{R_3} B_{G2} \frac{1}{sC_1} \frac{B_{G1}}{R_1} \frac{R_2}{(sC_2R_2 + 1)} \right] + \frac{B_{G3}}{R_3} \frac{R_2}{(sC_2R_2 + 1)} = s^2 + \frac{R_3 - R_2 B_{G3}}{R_2 R_3 C_2} s + \frac{B_{G1} B_{G2}}{R_1 R_3 C_1 C_2} = 0. \quad (8)$$

Condition of oscillation and oscillation frequency are:

$$B_{G3} \geq \frac{R_3}{R_2}, \quad (9)$$

$$\omega_0 = \sqrt{\frac{B_{G1} B_{G2}}{R_1 R_3 C_1 C_2}}. \quad (10)$$

Relation between generated amplitudes is:

$$\frac{V_{OUT1}}{V_{OUT2}} = \frac{B_{G2}}{j\omega_0 C_1 R_3} = -j \sqrt{\frac{R_1 C_2 B_{G2}}{R_3 C_1 B_{G1}}}, \quad (11)$$

$$V_{OUT1} = V_{OUT2} \sqrt{\frac{R_1 C_2 B_{G2}}{R_3 C_1 B_{G1}}} e^{\frac{\pi}{2}j}. \quad (12)$$

Simultaneous change of B_{G1} and B_{G2} ($B_{G1} = B_{G2} = B_{G1,2}$) tunes oscillation frequency linearly without influence of output amplitudes as is clear from (12). Sensitivities of ω_0 on parameters of active and passive elements are following:

$$S_{R_1}^{o_0} = S_{R_3}^{o_0} = S_{C_1}^{o_0} = S_{C_2}^{o_0} = -0.5, \quad (13)$$

$$S_{B_{G1}}^{o_0} = S_{B_{G2}}^{o_0} = 0.5, \quad S_{B_{G3}}^{o_0} = S_{R_2}^{o_0} = 0. \quad (14)$$

The modified solution of the oscillator from Fig. 3 is shown in Fig. 4. Resistor R_2 was saved in this modification and only 2R-2C based oscillator with four CC was obtained. This designation (2R-2C) was used in [40-41] for oscillators which contain only two resistors and two capacitors. However, CC_4 must be extended to two-output type (two Z ports) and then only four passive elements are needed. The CC_4 is more complicated than simple three-port CCII+ but for internal topology of CC it is no problem [4-5], [15-16]. The characteristic equation for the modified oscillator in Fig. 4 is:

$$\Delta_2 = s^2 + \frac{1 - B_{G3}}{R_3 C_2} s + \frac{B_{G1} B_{G2}}{R_1 R_3 C_1 C_2} = 0. \quad (15)$$

Oscillation frequency is given by formula (10) and CO is very simple: $B_{G3} \geq 1$. A relation between both produced

amplitudes equals to (11) and (12). Sensitivities of f_0 on circuit parameters are the same as in the first type of oscillator.

III. REAL BEHAVIOR AND DISCUSSION OF EXPERIMENTAL RESULTS

We choose first type of the oscillator for a detailed analysis, because it can be realized easily by available active elements. A circuit from Fig. 3 was extended by several passive elements. These elements are modeling the most important parasitic influences in the real circuit. Hatched resistors in Fig. 5 include intrinsic resistances of current inputs of used active elements or resistances of current outputs. Capacitors C_{p1} and C_{p2} were also added in order to represent important parasitic behavior. We used current mode multiplier EL2082 [42], diamond transistor OPA860 [27] and buffer OPA633 [43] for experimental purposes. The expected values of parasitics are derived from their models.

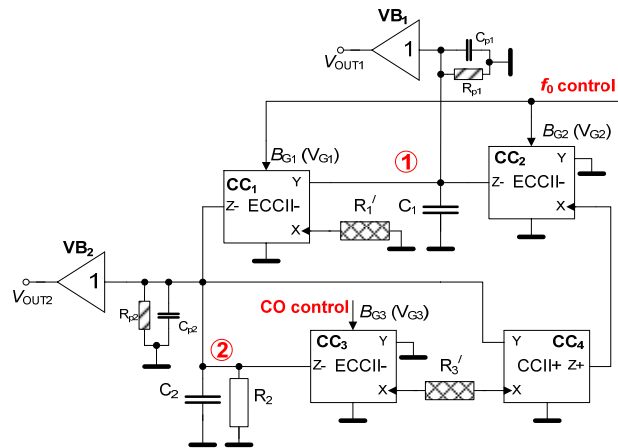

Figure 5. Important parasitic influences in the analyzed oscillator from Fig. 3

From Fig. 5 we can determine the following parameters: $R_{p1} \approx R_{Y_CC1} \parallel R_{Z_CC2} \parallel R_{inp_buff1}$, $C_{p1} \approx C_{Y_CC1} + C_{Z_CC2} + C_{inp_buff1}$, $R_{p2} \approx R_{Z_CC1} \parallel R_{Z_CC3} \parallel R_{Y_CC4} \parallel R_{inp_buff2}$, $C_{p2} \approx C_{Z_CC1} + C_{Z_CC3} + C_{Y_CC4} + C_{inp_buff2}$, $R_1' \approx R_1 + R_{X_CC1}$, $R_3' \approx R_3 + R_{X_CC3} + R_{X_CC4}$. Datasheet information indicates values as follows: $R_{Y_CC1,2,3} \approx 2 \text{ M}\Omega$, $R_{Z_CC1,2,3} \approx 1 \text{ M}\Omega$ and $C_{Y_CC1,2,3} \approx 2 \text{ pF}$, $C_{Z_CC1,2,3} \approx 5 \text{ pF}$, $R_{X_CC1,2,3} \approx 95 \Omega$ (EL2082 [42]); $R_{Y_CC4} \approx 0.455 \text{ M}\Omega$, $C_{Y_CC4} \approx 2 \text{ pF}$, $R_{Z_CC4} \approx 54 \text{ k}\Omega$, $C_{Z_CC4} \approx 2 \text{ pF}$, $R_{X_CC4} \approx 13 \Omega$ (OPA860 [27]); input diamond buffer of OPA860 [27] characteristics $Z_{inp_buff2} \approx 1 \text{ M}\Omega / 2 \text{ pF}$; $Z_{inp_buff1} \approx 1.5 \text{ M}\Omega / 1.6 \text{ pF}$ (OPA633 [43]). The resulting values are: $R_{p1} \approx 462 \text{ k}\Omega$, $R_{p2} \approx 192 \text{ k}\Omega$, $R_1' \approx 915 \Omega$, $R_3' \approx 928 \Omega$; $C_{p1} \approx 8.6 \text{ pF}$, $C_{p2} \approx 14 \text{ pF}$. We suppose $R_{X_CC2} \ll R_{Z_CC4}$. We can neglect these parameters because $95 \Omega \ll 54 \text{ k}\Omega$. Equations for oscillation frequency and CO considering real influences are:

$$\omega_0' = \sqrt{\frac{B_{G1} B_{G2} \left(\frac{R_2 R_{p2}}{R_2 + R_{p2}} \right) R_{p1} + R_1' \left[R_3' - B_{G3} \left(\frac{R_2 R_{p2}}{R_2 + R_{p2}} \right) \right]}{R_1' \left(\frac{R_2 R_{p2}}{R_2 + R_{p2}} \right) R_3' R_{p1} C_1' C_2'}}}, \quad (16)$$

$$B'_{G3} \geq \frac{R'_3 \left[\left(\frac{R_2 R_{p2}}{R_2 + R_{p2}} \right) C'_2 + R_{p1} C'_1 \right]}{\left(\frac{R_2 R_{p2}}{R_2 + R_{p2}} \right) R_{p1} C'_1} \quad (17)$$

Careful analysis reveals in equation (16) that

$$B_{G1} B_{G2} \left(\frac{R_2 R_{p2}}{R_2 + R_{p2}} \right) R_{p1} \gg R'_1 \left[R'_3 - B_{G3} \left(\frac{R_2 R_{p2}}{R_2 + R_{p2}} \right) \right] \quad (18)$$

Significant influence exists only for $B_{G1,2} \rightarrow 0$.

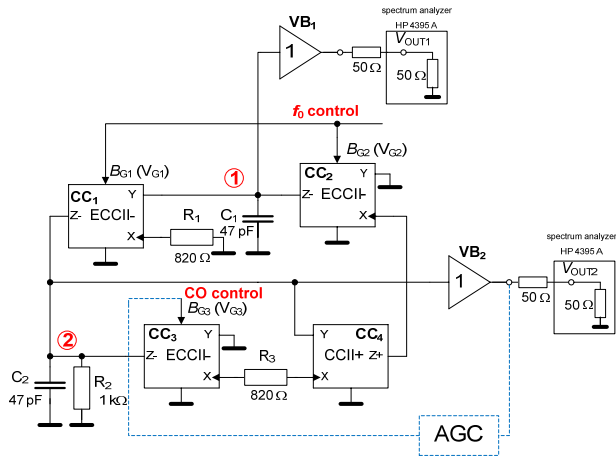

Figure 6. Configuration of experimentally tested oscillator

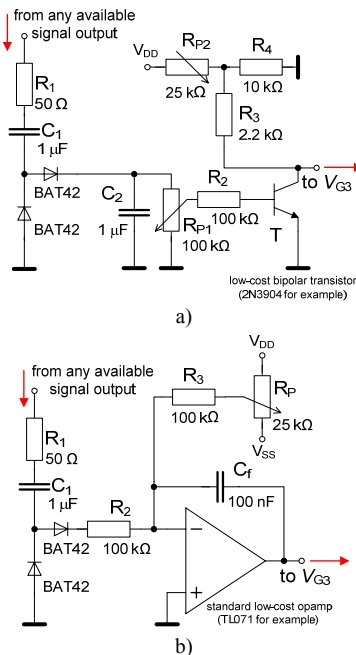

Figure 7. Two types of AGC for experimental purposes: a) based on BJT, b) based on opamp

The circuit shown in Fig. 3 was experimentally tested and we obtained the following results. For better and clearer understanding, particular measured circuit with designed values and measuring devices included is shown in Fig. 6. For ECCIs (CC_1 - CC_3), modeled by EL2082 multiplier, $B_G \approx V_G$ [42] is valid. Selected values of passive elements are $R_1 = R_3 = 820 \Omega$, $R_2 = 1 \text{ k}\Omega$, $C_1 = C_2 = 47 \text{ pF}$. Supply voltage is symmetrical $V_{DD} = +5 \text{ V}$ and $V_{SS} = -5 \text{ V}$. In accordance to analysis of parasitic influences, it is clear that real parameters of active elements play important role. Parasitic capacitances have main impact on accuracy of f_0

because they are comparable to the working values C_1 and C_2 . Tolerances of C_1 and C_2 are very important too. Some estimations based on above discussion of parasitic elements are given: $R'_1 \approx 915 \Omega$, $R'_3 \approx 928 \Omega$, $C'_1 \approx 56 \text{ pF}$, $C'_2 \approx 61 \text{ pF}$.

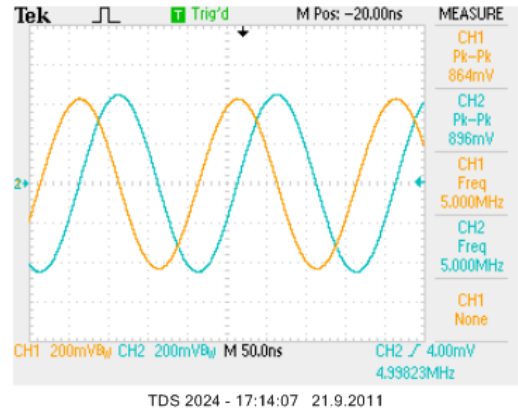

Figure 8. Transient responses of oscillator (when AGC from Fig. 7a was used) for $f_0 = 5 \text{ MHz}$

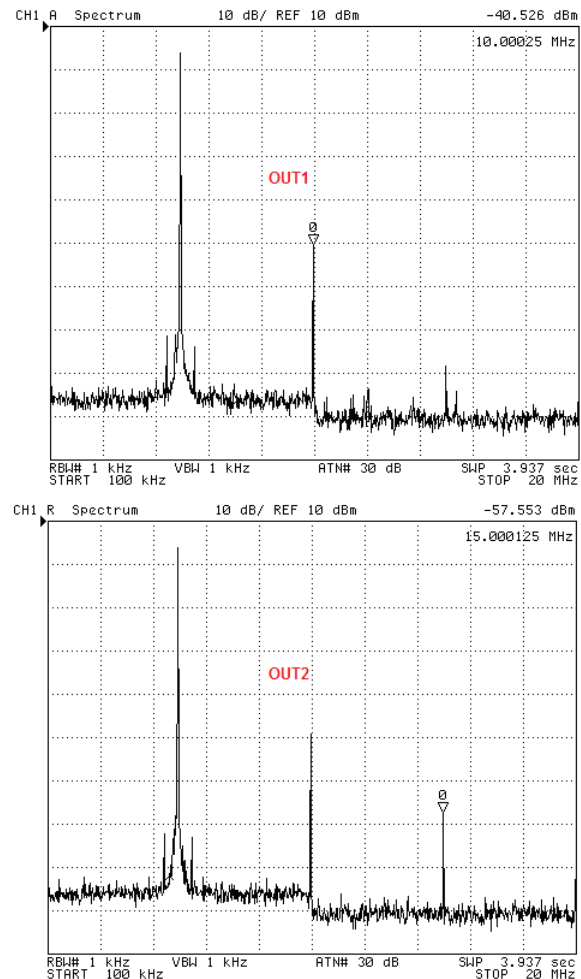

Figure 9. Spectral analysis for both outputs (AGC from Fig. 7a) for $f_0 = 5 \text{ MHz}$

However, tolerances of passive elements and parasitics of printed circuit board (PCB) were not considered. Experimental verification was made with two different types of very simple inertial AGC circuit (Fig. 7). These circuits are suitable for voltage control of CO in similar oscillator solutions. The AGC circuits contain cascade diode doubler. The first type of AGC is based on very simple common-emitter DC amplifier with bipolar transistor. The function is

based on nonlinear input-output transfer characteristic of this amplifier. The second type of AGC uses common opamp. Potentiometers are necessary for careful and very fine adjusting of CO.

The transient responses and spectral analysis of the oscillator with first type of AGC (Fig. 7a) are in Fig. 8 and Fig. 9. Results are for $f_0 = 5$ MHz ($B_{G1,2} = 1.63$).

The transient responses and spectral analysis of the oscillator with second type of AGC (Fig. 7b) are shown in Fig. 10 and Fig. 11 for same values of $B_{G1,2}$ as in previous case. The second type of AGC (Fig. 7b) offers larger suppression of higher harmonic components and therefore lower THD for nearly equal amplitudes, see Fig. 8 - Fig. 11.

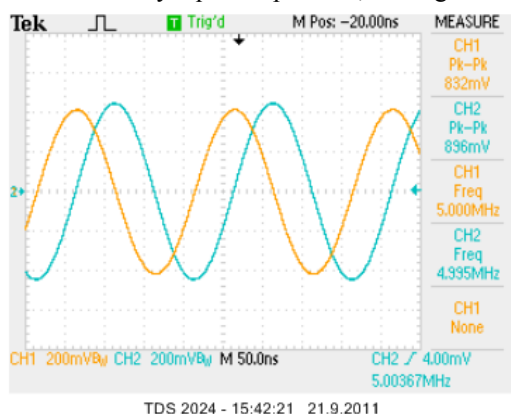

Figure 10. Transient responses of oscillator (when AGC from Fig. 7b was used) for $f_0 = 5$ MHz

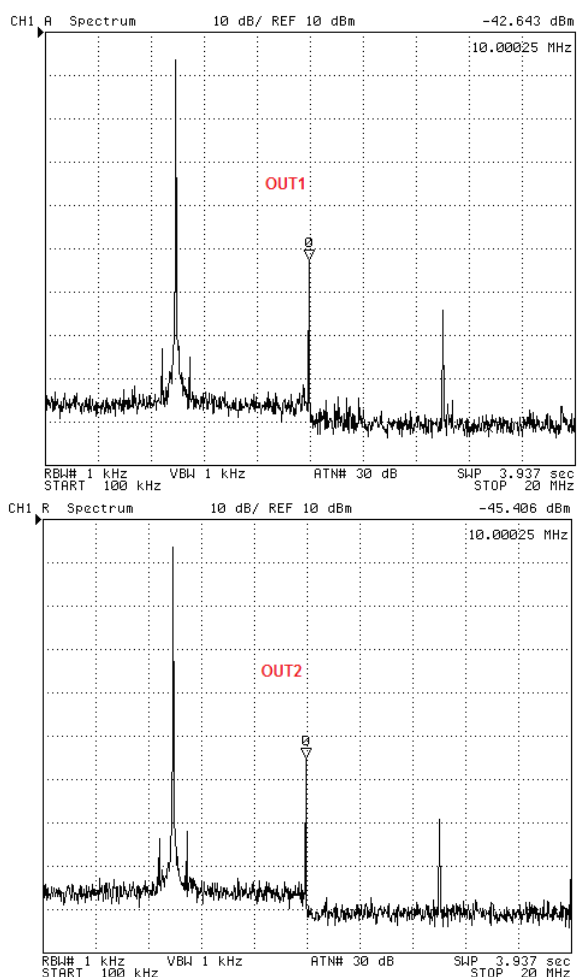

Figure 11. Spectral analysis for both outputs (AGC from Fig. 7b) for $f_0 = 5$ MHz

In Fig. 12 ideal, expected and measured dependences of f_0 on current gain $B_{G1,2}$ are compared. Ideal dependence was obtained from eq. (10), where only expected values $R_1' \approx 915 \Omega$, $R_3' \approx 928 \Omega$ were considered. Ideal range of f_0 adjusting is from 0.25 MHz to 8.84 MHz. Expected range is from 0.20 MHz to 7.13 MHz. The expected curve was calculated from (16). Range of f_0 adjusting from 0.13 MHz to 7.87 MHz was gained from measurement. All traces in Fig. 12 were obtained for $B_{G1,2}$ from 0.06 to 2.4 ($V_{G1,2}$ from 0.06 to 2.6 V). We have measured and evaluated dependences of output level and total harmonic distortion (THD) on f_0 . Results are in Fig. 13 and Fig. 14.

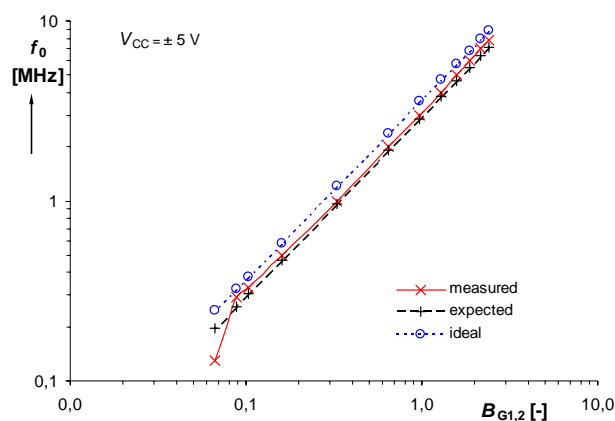

Figure 12. Dependence of f_0 on $B_{G1,2}$

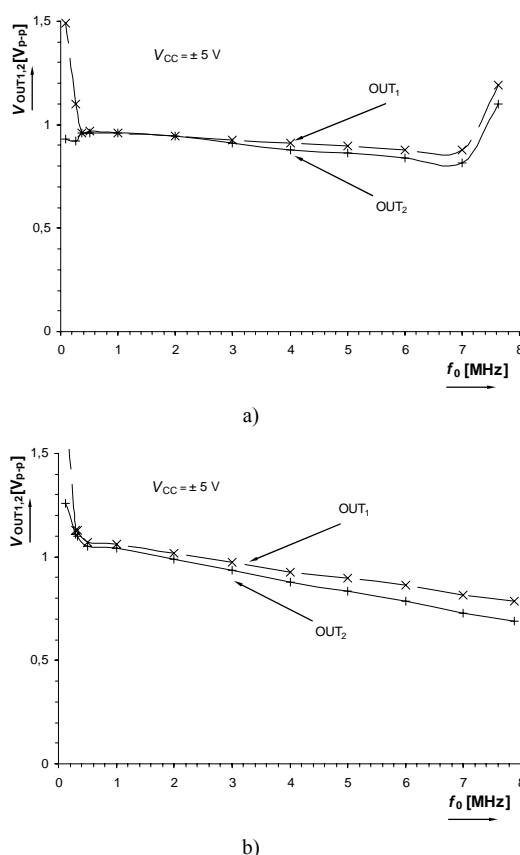

Figure 13. Dependence of voltage level of output signals on f_0 for oscillator using: a) AGC in Fig. 7a, b) AGC in Fig. 7b

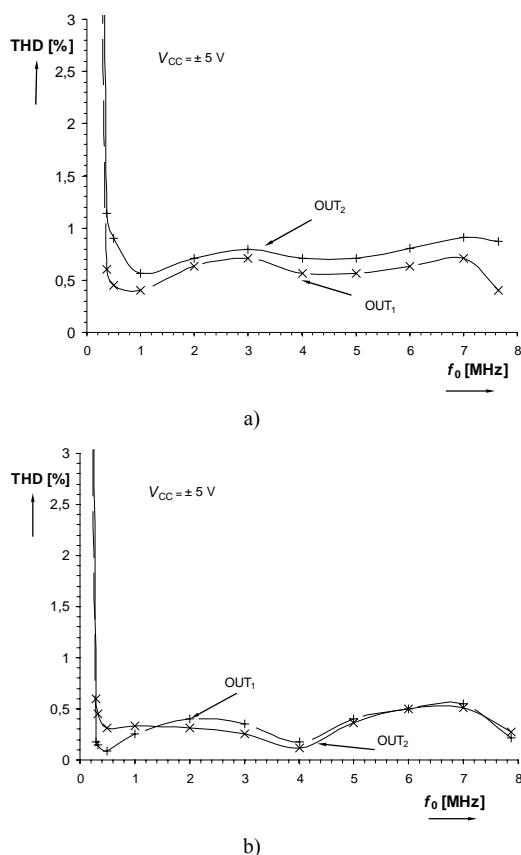

Figure 14. Dependence of THD on f_0 for oscillator using: a) AGC in Fig. 7a, b) AGC in Fig. 7b

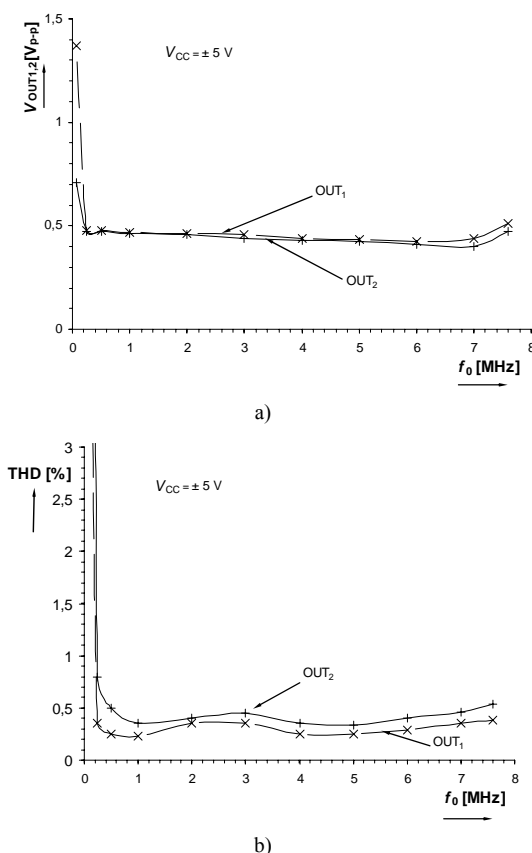

Figure 15. Results of readjusted AGC (Fig. 7a): a) output levels in dependence on f_0 , b) dependence of THD on f_0

We can see fluctuation of THD between 0.4 and 0.9 % in almost whole range of f_0 (AGC type from Fig. 7a). AGC type in Fig. 7b (with opamp) provides lower THD between

0.1 and 0.6 %, but falling of output level with increasing of f_0 is slightly faster. Therefore, better setting of the AGC circuit in Fig. 7a for next experiments was used. Output voltage was changed to half of values used in measurement documented in Fig. 13a and THD was decreased. Values are then between 0.2 and 0.5 %. This setting also improves stability of output level. The dependence of $V_{OUT1,2}$ on f_0 is now nearly constant. The results are shown in Fig. 15.

The proposed circuit in Fig. 6 can be easily simulated in PSpice program. All used commercially available active elements (EL2082, OPA860, etc.) have models that are included in PSpice libraries. We provided statistical Monte-Carlo analyses of the discussed oscillator for typical fabrication tolerances of passive elements (see Tab. 1) and Gaussian distribution. Fabrication uncertainty of key parameters of the active elements, that are responsible for control of oscillation frequency ($B_{1,2}$), was simulated by variation of $V_{G1,2}$ (also in Tab. 1). The initial settings of oscillator was provided for $f_0 = 5$ MHz. Table 1 contains the maximal and minimal (the most pessimistic case) f_0 , more optimistic (close to the real case) standard deviation (sigma) and mean value of f_0 . The analyses confirmed expected sensitivities of f_0 on passive and active parameters in equations (13) and (14). High tolerances of $V_{G1,2}$ ($B_{1,2}$) mean high dispersion of expected f_0 . Figure 16 shows an example of Monte-Carlo set results.

Tab. 1. Results of Monte-Carlo analysis (100 runs)

tolerances [%]			mean	min	max	sigma
R_1, R_2, R_3	C_1, C_2	V_{G1}, V_{G2}	[MHz]	[MHz]	[MHz]	[kHz]
1	5	5	4.986	4.809	5.157	70.4
1	5	10	4.982	4.682	5.249	111.6

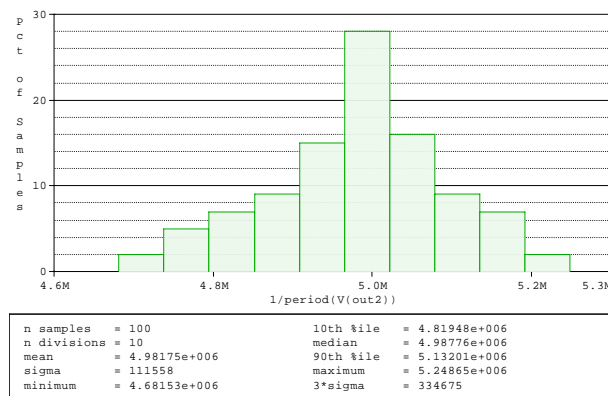

Figure 16. Histogram of Monte-Carlo analysis (tol. 10% $V_{G1,2}$, 5% C , 1% R)

IV. CONCLUSION

In this paper, we discussed features of quadrature oscillator using ECCII and CCII elements, which was systematically designed by two-loop integrators synthesis and help of signal-flow graph approach for better understanding. In recent years, many works dealing with the quadrature oscillator synthesis and design have been published. However, our approach to this problem was based more practically and mainly on quality of produced signals, i.e. precise electronic adjusting of the CO (two AGCs) and tuning of f_0 with minimal fluctuances of output level and low THD in comparison to common similar research works (simpler solutions employing minimal number of active elements for example). We obtained more accurate equations for oscillator design from more detailed

analyses of influences of real active elements which are useful for calculation of expected results. Experimental verifications with two very simple AGC circuits were provided and compared. Output amplitudes are not influenced by tuning of f_0 (this is typical for simpler types of oscillators) and the proposed method of current gain control of CO allows simple implementation of AGC. Really good results (nearly constant output amplitudes for wideband tuning of oscillation frequency and low THD) were obtained for optimal setting of AGC.

REFERENCES

- [1] A. Sedra, K. C. Smith, "A second generation current conveyor and its applications," *IEEE Transaction on Circuit Theory*, vol. CT-17, no. 2, pp. 132-134, 1970.
- [2] J. A. Svoboda, L. M. Gory, S. Webb, "Applications of commercially available current conveyor," *Int. Journal of Electronics*, vol. 70, no. 1, pp. 159-164, 1991.
- [3] D. Biolek, R. Senani, V. Biolkova, Z. Kolka, "Active elements for analog signal processing: Classification, Review, and New Proposal," *Radioengineering*, vol. 17, no. 4, pp. 15-3, 2008.
- [4] R. Raut, M. N. S. Swamy, *Modern Analog Filter Analysis and Design: A practical approach*. Weinheim, Germany: Wiley-VCH Verlag GmbH and Co. KGaA, 2010.
- [5] A. Fabre, O. Saaid, F. Wiest, C. Boucheron, "High frequency applications based on a new current controlled conveyor," *IEEE Trans. on Circuits and Systems - I*, vol. 43, no. 2, pp. 82-91, 1996.
- [6] S. B. Salem, M. Fakhfakh, D. S. Masmoudi, M. Loulou, P. Loumeau, N. Masmoudi, "A high performance CMOS CCII and high frequency applications," *Analog Integrated Circuits and Signal Processing*, vol. 49, no. 1, pp. 71-78, 2006.
- [7] H. Barthelemy, M. Fillaud, S. Bourdel, J. Gaunery, "CMOS inverters based positive type second generation current conveyors," *Analog Integrated Circuits and Signal Processing*, vol. 50, no. 2, pp. 141-146, 2007.
- [8] I. Eldbib, V. Musil, "Self-cascoded Current Controlled CCII Based Tunable Band Pass Filter," in *Proc. 18th Int. Conf. Radioelektronika*, Praha, 2008, pp. 1-4.
- [9] W. Surakampontorn, W. Thitimajshima, "Integrable electronically tunable current conveyors," *IEE Proceedings-G*, vol. 135, no. 2, pp. 71-77, 1988.
- [10] S. Minaei, O. K. Sayin, H. Kuntman, "A new CMOS electronically tunable current conveyor and its application to current-mode filters," *IEEE Trans. on Circuits and Systems - I*, vol. 53, no. 7, pp. 1448-1457, 2006.
- [11] A. Marcellis, G. Ferri, N. C. Guerrini, V. Scotti, A. Trifiletti, "The VGC-CCII: a novel building block and its application to capacitance multiplication," *Analog Integrated Circuits and Signal Processing*, vol. 58, no. 1, pp. 55-59, 2009.
- [12] W. Tangsrirat, "Electronically Tunable Multi-Terminal Floating Nullor and Its Application," *Radioengineering*, vol. 17, no. 4, pp. 3-7, 2008.
- [13] S. Shi-Xiang, Y. Guo-Ping, C. Hua, "A new CMOS electronically tunable current conveyor based on translinear circuits," in *Proc. 7th Int. Conf. on ASIC*, Guilin, 2007, pp. 569-572.
- [14] N. Herencsar, A. Lahiri, K. Vrba, J. Koton, "An electronically tunable current-mode quadrature oscillator using PCAs," *Int. Journal of Electronics*, vol. 99, no. 5, pp. 609-621, 2012.
- [15] G. Souliotis, C. Psychalinos, "Electronically controlled multiphase sinusoidal oscillators using current amplifiers," *International Journal of Circuit Theory and Applications*, vol. 37, no. 1, pp. 43-52, 2009.
- [16] M. Kumngern, J. Chanwutium, K. Dejhan, "Electronically tunable multiphase sinusoidal oscillator using translinear current conveyors," *Analog Integrated Circuits and Signal Processing*, vol. 65, no. 2, pp. 327-334, 2010.
- [17] M. Kumngern, S. Junnapiya, "A sinusoidal oscillator using translinear current conveyors," in *Proc. Asia Pacific Conference on Circuits and Systems (APPCAS)*, Kuala Lumpur, 2010, pp. 740-743.
- [18] J. Koton, N. Herencsar, O. Cicekoglu, K. Vrba, "Current-mode KHN equivalent frequency filter using ECCII," in *Proc. 33th Telecommunication and Signal Processing Conf.*, Vienna, 2010, pp. 27-30.
- [19] J. Jerabek, R. Sotner, K. Vrba, "Fully-differential current amplifier and its application to universal and adjustable filter," in *Proc. International Conference on Applied Electronics APPEL*, Pilsen, 2010, pp. 141-144.
- [20] R. Sotner, J. Jerabek, R. Prokop, K. Vrba, "Current gain controlled CCTA and its application in quadrature oscillator and direct frequency modulator," *Radioengineering*, vol. 20, no. 1, pp. 317-326, 2012.
- [21] R. Sotner, J. Jerabek, B. Sevcik, T. Dostal, K. Vrba, "Novel Solution of Notch/All-pass Filter with Special Electronic Adjusting of Attenuation in the Stop Band," *Elektronika I Ir Elektrotechnika*, vol. 16, no. 7 (113), pp. 37-42, 2011.
- [22] R. Sotner, Z. Hrubos, J. Slezak, T. Dostal, "Simply Adjustable Sinusoidal Oscillator Based on Negative Three-Port Current Conveyors," *Radioengineering*, vol. 19, no. 3, pp. 446-453, 2010.
- [23] R. Sotner, Z. Hrubos, B. Sevcik, J. Slezak, J. Petrzela, T. Dostal, "An example of easy synthesis of active filter and oscillator using signal flow graph modification and controllable current conveyors," *Journal of Electrical Engineering*, vol. 62, no. 5, pp. 258-266, 2011.
- [24] D. Biolek, A. Lahiri, W. Jaikla, M. Siriruchyanun, J. Bajer, "Realization of electronically tunable voltage-mode/current-mode quadrature sinusoidal oscillator using ZC-CG-CDBA," *Microelectronics Journal*, vol. 42, no. 10, pp. 1116-1123, 2011.
- [25] J. Bajer, D. Biolek, "Digitally Controlled Quadrature Oscillator Employing Two ZC-CG-CDBAs," in *Proc. Conference on Electronic Devices and Systems EDS IMAPS CS*, Brno, 2009, pp. 298-303.
- [26] D. Biolek, V. Biolkova, "Implementation of Active Elements for Analog Signal Processing by Diamond Transistors," in *Proc. Conference on Electronic Devices and Systems EDS IMAPS CS*, Brno, 2009, pp. 304-309.
- [27] OPA860: Wide Bandwidth Operational Transconductance Amplifier and Buffer, Texas Instruments [online]. 2005, last modified 8/2008 [cit.28.7.2011]. available at URL: <<http://focus.ti.com/lit/ds/symlink/opa860.pdf>>
- [28] H. Alzaher, "CMOS Digitally Programmable Quadrature Oscillators," *International Journal of Circuit Theory and Applications*, vol. 36, no. 8, p. 953-966, 2008. DOI: 10.1002/cta.479.
- [29] S. S. Gupta, R. Senani, "State variable synthesis of single resistance controlled grounded capacitor oscillators using only two CFOAs," *IEE Proceedings on Circuits, Devices and Systems*, vol. 145, no. 2, p. 135-138, 1998.
- [30] S. S. Gupta, R. Senani, "State variable synthesis of single-resistance-controlled grounded capacitor oscillators using only two CFOAs: additional new realizations," *IEE Proceedings on Circuits Devices and Systems*, vol. 145, no. 6, pp. 415-418, 1998.
- [31] A. Lahiri, "Deriving (MO) (I) CCCII Based Second-order Sinusoidal Oscillators with Non-interactive Tuning Laws using State Variable Method," *Radioengineering*, vol. 20, no. 1, pp. 349-353, 2011.
- [32] T. Tsukutani, Y. Sumi, Y. Fukui, "Electronically tunable current-mode OTA-C biquad using two-integrator loop structure," *Frequenz*, vol. 60, no. 3-4, pp. 53-56, 2006.
- [33] J. Jerabek, K. Vrba, "Multiple-Input Multiple-Output Universal Filter Using Current Followers," in *Proc. 31th Telecommunication and Signal Processing Conf.*, Budapest, 2008, pp. 29-32.
- [34] T. Dostal, "Filters with multi-loop feedback structure in current mode," *Radioengineering*, vol. 12, no. 3, pp. 6-11, 2003.
- [35] T. Tsukutani, Y. Sumi, Y. Fukui, "Novel current-mode biquad filter using OTAs and DO-CCII," *Int. Journal of Electronics*, vol. 94, no. 2, pp. 99-105, 2007.
- [36] M. T. Abuelmaatti, A. Bentrchia, "A novel mixed-mode OTA-C universal filter," *Int. Journal of Electronics*, vol. 92, no. 7, pp. 375-383, 2005.
- [37] Y. Sun, J. K. Fidler, "Structure Geretion of Current-Mode Two Integrator Dual output-OTA Grounded Capacitor Filters," *IEEE Transaction on Circuits and Systems II: Analog and Digital Signal Processing*, vol. 43, no. 9, pp. 659-663, 1996.
- [38] S. J. Mason, "Feedback Theory: Further properties of Signal Flow Graphs," *Proceedings of IRE*, vol. 44, no. 7, pp. 920-926, 1956.
- [39] C. J. Coates, "Flow-graph Solution of Linear Algebraic Equations," *IRE Transactions on Circuit Theory*, vol. 6, no. 2, pp. 170-187, 1959.
- [40] A. Lahiri, "Current-mode variable frequency quadrature sinusoidal oscillator using two CCs and four passive components including grounded capacitors," *Analog Integrated Circuits and Signal Processing*, vol. 71, no. 2, pp. 303-311, 2012.
- [41] A. Lahiri, "Current-mode variable frequency quadrature sinusoidal oscillator using two CCs and four passive components including grounded capacitors: a supplement," *Analog Integrated Circuits and Signal Processing*, vol. 68, no. 1, pp. 129-131, 2011.
- [42] EL2082: Current-Mode Multiplier, Intersil (Elantec) [online]. 1996, last modified 2003 [cit.28.7.2011]. available at URL: <<http://www.intersil.com/data/fn/fn7152.pdf>>
- [43] OPA633: High speed buffer amplifier, Texas Instruments [online]. 1993, last modified 9/2000 [cit.28.7.2011]. available at URL: <<http://focus.ti.com/lit/ds/symlink/opa633.pdf>>